

agility • safety • efficacy • technology • quality



Vertical elevation platform



*By professionals,  
for professionals*



## Our star product

This is a personal lift that can be installed either in homes or at the workplace. The hydraulic equipment is exclusively designed for carrying people, providing an unprecedented level of comfort. In addition to complying with European Regulation 81.41, it also guarantees maximum safety.

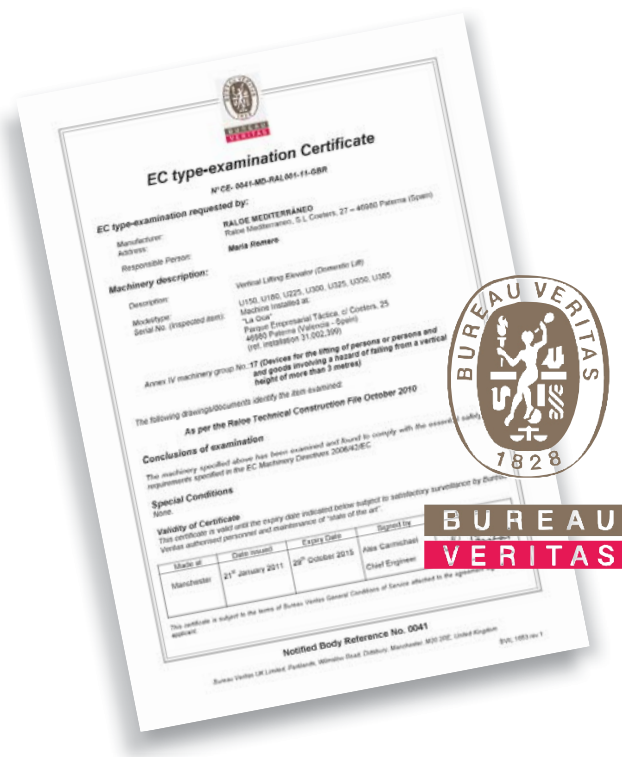

### • Advantages

**Maximum safety:** we have extensively studied its structure in order to guarantee the lift safety levels.

**Custom-designed to meet your needs:** we offer a wide range of models to ensure that the finishes meet your specific needs.

**Energy efficiency:** it operates with any household socket and incurs minimal expenses, consuming as much energy as a hairdryer.

**Optimisation of space:** takes advantage of up to 70% of the shaft for the lift car.

**Emergency:** equipped with a rescue system that enables the evacuation of people in case of a power outage.

**Gearless:** Ask us for the new Gearless DomesticLift

# Technical Information

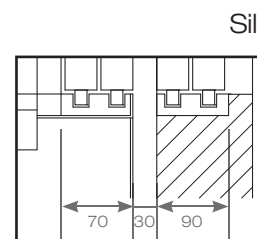
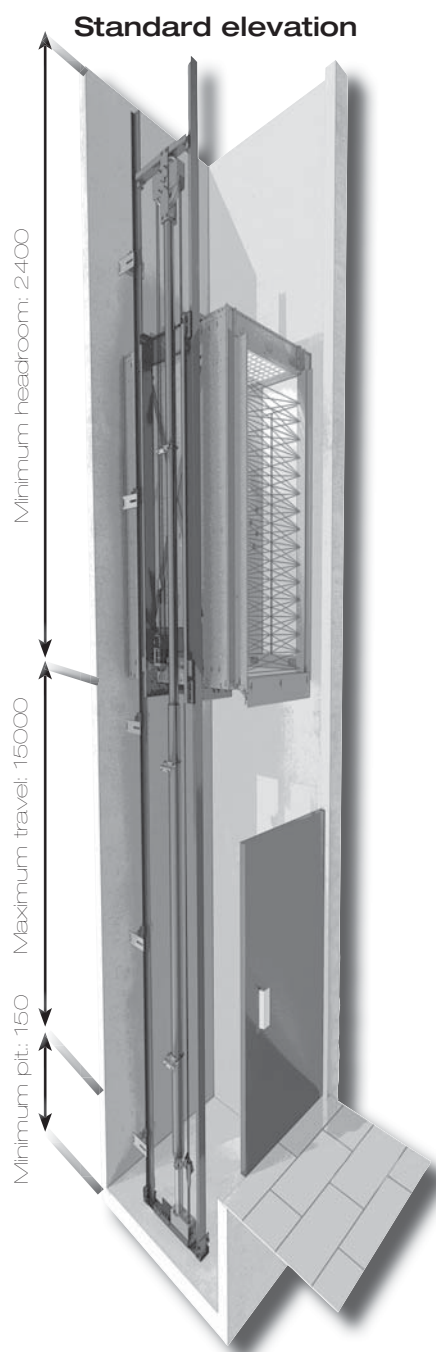

<b>Minimum pit</b>	150 mm.
<b>Maximum travel</b>	15.000 mm.
<b>Minimum headroom</b>	2.400 mm. <sup>(1)</sup>

<sup>(1)</sup> In case the car is supplied without doors.

Obligatory prefabricated cupboard (Model E400) or Machine room.

General specifications		Interesting data	
Hydraulic indirect acting	2:1	Unlocking zone	100 mm.
Speed	0,15 m/s	Upron height	100 mm.
Car frame	UF-400		
Car rail guides	T70		
2 ropes Seale	10x19+1		

## Car operating panel

Vertical plate, horizontal or column shaped.

## Operating panel elements

- Push buttons on landings: In case the car has no doors, they will have to be continuously pressed in order to move the domestic lift.
- Alarm button.
- Stop button.
- Restricted use of key switch. Without key switch the lift does not work.
- Lift specifications plate.

## Landing operating panels

Supplied with push button or with a key switch.

## Communication system

Own home landline telephone set.

## Public buildings

Bidirectional communication.

# Guarantee

## CE Type test.

Directive 2006/42/CE  
Harmonised standards

- EN-ISO 12100-1
- EN-ISO 12100-2
- EN-14121-1
- EN-60204
- EN-81-41
- EN-12015/12016

## Manufacturing declaration for car.

Manufacturing declaration for hydraulic lift frames.

## Certificates according to component standards:

- Landing doors lock.
- Safety gear valve.
- Instant safety gear IT 100 - S.
- Fire door tests.
- Hydraulic hose test certificates.

# Safety

## Detection system

**Security detection system** installed on the lowest floor door. Will operate when using the emergency key, driving the contact switch which avoids the car motion and **roof jamming**.

## Auto levelling system



Avoids height differences between car and landing floors.

## Instantaneous safety gear system

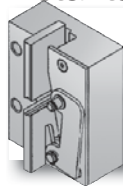

Certified device acting in case of breakage of one of the two ropes, taking care of user's safety.

## Mechanic stop in pit and headroom.

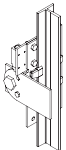

Placed in the guide, it shall decline not more than entering the pit or rise to the car ceiling in order to stop so that car can be caught in the pit or in the headroom by the maintainer.

## Safety Gear Valve



Hydraulic equipment is provided with a certified valve, acting instantaneously in case of leak or breakage of the hydraulic circuit.

## Stop button in pit



To **stop** electrical flow before entering the shaft.

## Overweight pressure switch



Installation includes a pneumatic pressure switch with an acoustic buzzer avoiding car motion in case of overweight.

## Machine room

In case of no space in the building for the machine room, a cabinet can be provided. Perfect for reduced spaces and easy to install.



## Safety without doors

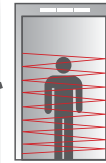

Without doors in car a light curtain avoids the car to start or stops its movement, if it detects an obstacle in the working zone.

## Door safety



With automatic car and landing doors a photocell avoids user to be hit by the door.

## Security upon



Security upon in lift car avoids shaft trapping.

## Detection system

**Security detection system** installed on the lowest floor door. Will operate when using the emergency key, driving the contact switch which avoids the car motion and **shaft jamming**.

## Floor lowering security system

In case of a power outage, the emergency light in the car turns on. The passenger can get off at whatever inferior level, pushing the button of the desired level.

# Comfort

## Silent contactors

We offer the possibility to add silent contactors in the electrical board.



## Motor

It's offered the possibility to have the motor submerged in oil to reach a noise reduction of 6 Db. 2 speed motor (0,15/0,0375), for a better stop comfort.

## Double security valve

Hydraulic kit with double valve system to avoid car uncontrolled movements in case of mechanical failure of the main valve.

# Drawings of landing

**1 Entrance back car frame**  
Semi-automatic door

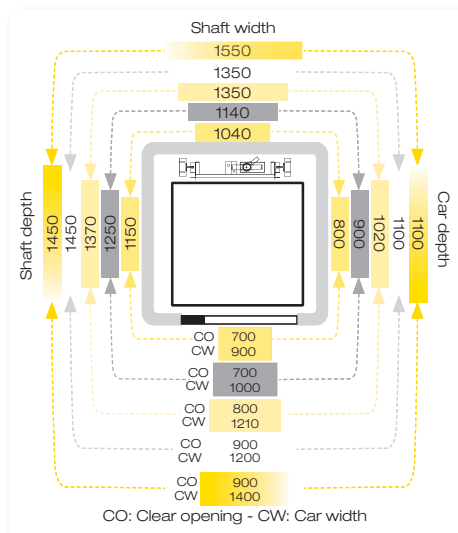

**1 Entrance side car frame**  
Semi-automatic door

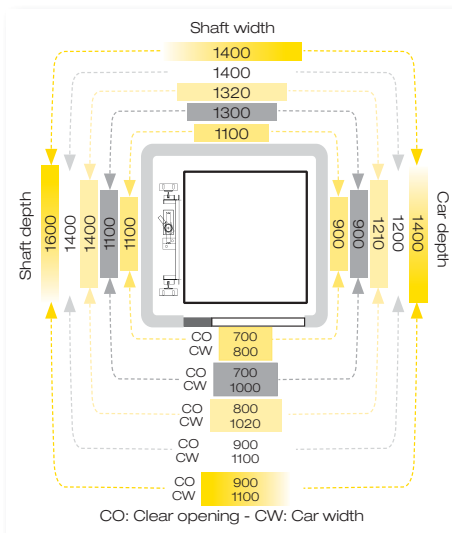

**Double entrance 90° side car frame**  
Semi-automatic door

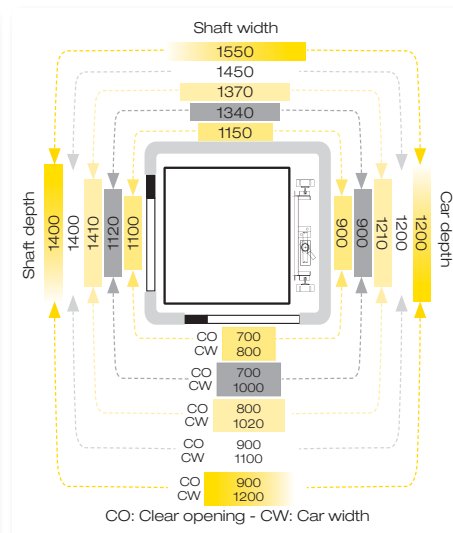

**Double entrance 180°**  
Semi-automatic door

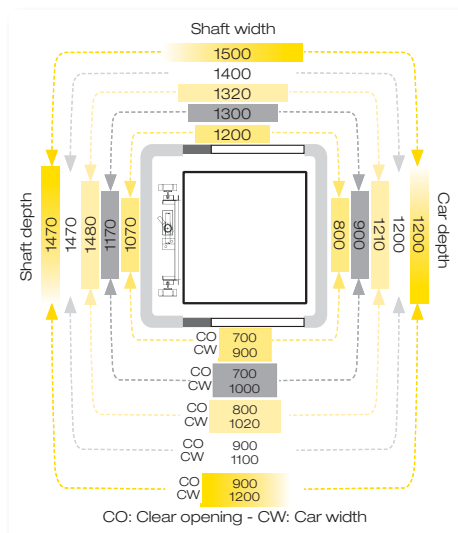

**1 Entrance side car frame**  
Automatic door\*

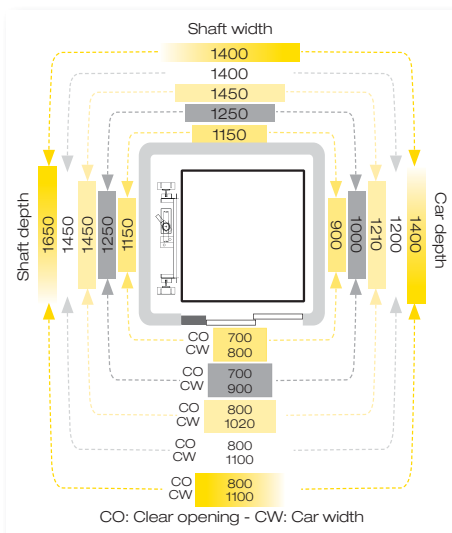

**Double entrance 90° side car frame**  
Automatic door\*

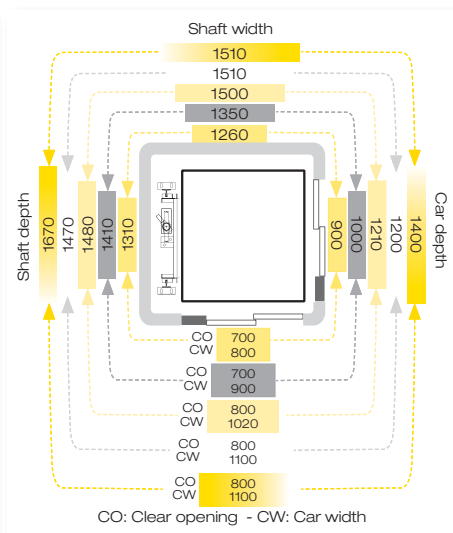

**Double entrance 180°**  
Automatic door\*

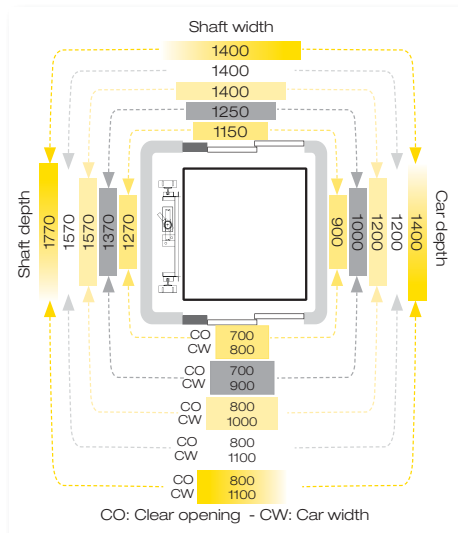

180 Kg	
225 Kg	
325 Kg	
350 Kg	
385 Kg	

\* 3 panels side opening in case of 180kg, in other loads 2 panels side opening

# Decoration

Rang finitions:

 Standard  Medium  Premium

## Ceilings

 Perforated plate



Type 3



Type 4



Type 5

## Panels

 Skinplate



Creme



Grey



Stainless Steel

 Melamines



Cherry tree

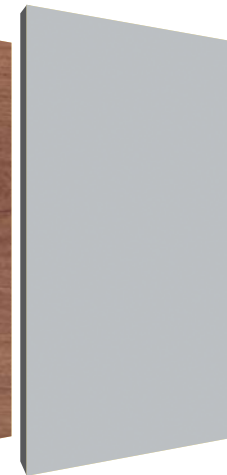

Grey



Beech

## Floors

 Rubber circles

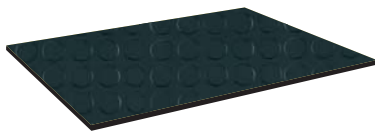

Black

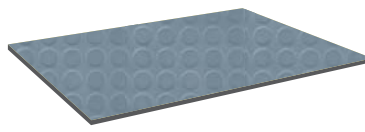

Grey

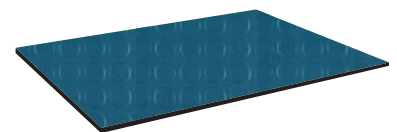

Blue

 Nonslip rubber



Beige

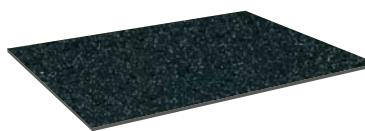

Black

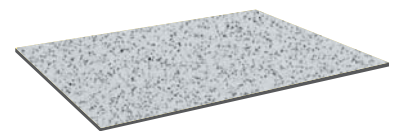

Grey

 Linoleum

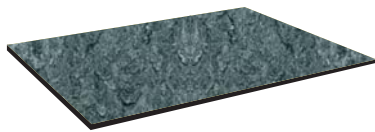

Dark Grey

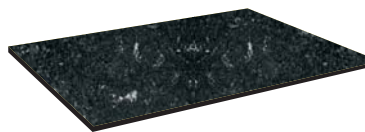

Black

 Stainless Steel



Teardrop Plate

Notice: Possibility of delivery of car with galvanized sheet for its complete decoration.

Shaded glass



Skinplate with halogen lights

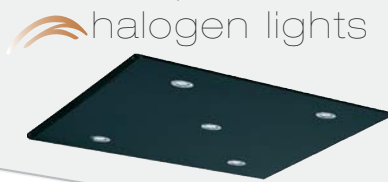

Stainless steel with halogen lights



Polished stainless steel or satin.  
Option LED

Laminado



Beech

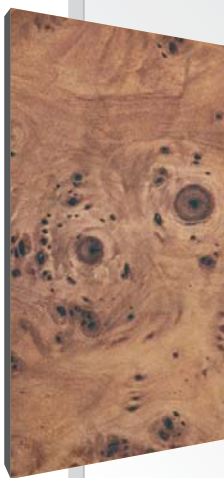

Ambar Erable



Blue China

Stainless



Satin

Glass



Entire panel



Vinyl

Granit

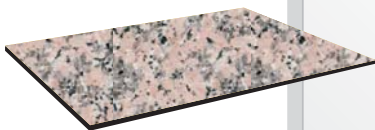

Porriño pink



Cristal white



Pearl grey

Pergo (wood)



White Pine



Dark Poplar Bark

Aluminium



Damero

Silestone



Dafne beige

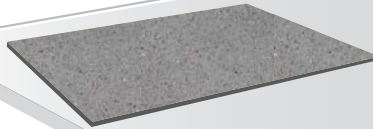

Expo grey



Stellar black

# Imagine

## Car operating panel (C.O.P.)

Epsilon series



Glass



Handrail type



B50 series



Retro position indicator



### Buttons



Bas 120



Epsilon



B 50 Q  
(50 x 50 mm)



B 50 R  
(50 x 50 mm)

### Handrail



Tubular curved skinplate



Tubular curved stainless steel



Tubular straight  
(to be placed only in front of the entrance)

### Mirrors

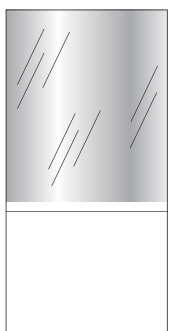

1/2 height



3/4 height

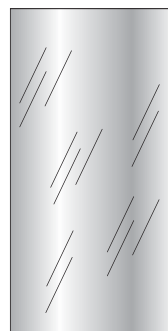

Complete

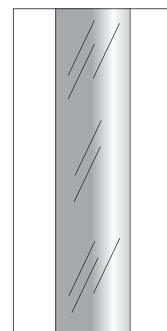

Vertical slat

Stainless steel finishing.  
\*Ask for other finishing (destressed white, bronze)



# Doors

## Semiautomatic



 Vision panel



 Big vision panel



 Complete glass

## Automatic



 Primed, \* stainless steel



 Big vision panel



 Folding door  
Big vision panel



 Complete glass  
stainless steel frame

## Door finishings

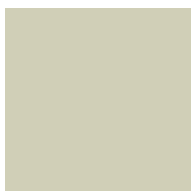

 RAL 7032\*\*



 Stainless steel  
satin



 Stainless steel  
pigskin

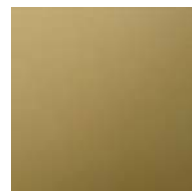

 Stainless steel  
gold

\* The prime of the doors allows repainting according to the home decoration.

\*\* Availability of diferent RAL colours. Please ask.

The customer can integrate the landing operating panel in the wall.

# Car options

M03 - L03



Walls



Cherry Tree  
Melamine



Formica  
Seringa 2273

Floors



Nonslip rubber  
beige



Nonslip rubber  
black

Panoramic



Walls



Melamine  
creme



Formica  
Ambar Erable

Floors

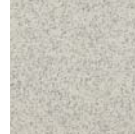

Nonslip rubber  
beige



Linoleum  
dark grey

I01



Walls



Satin steel  
stainless



Gold steel  
stainless

Floors

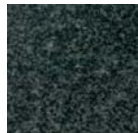

Granit black  
South Africa



Rubber circles  
black

Elegance



Walls



Formica  
Stony Sand



Formica  
Beech

Floors

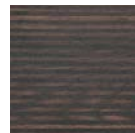

Dark Poplar  
Bark



Silestone  
Dafne beige

S01



Walls

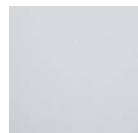

Skinplate  
grey

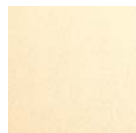

Skinplate  
creme

Floors

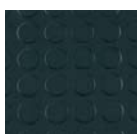

Rubber circles  
black

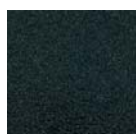

Nonslip rubber  
black

Ocean



Walls



Green steel  
stainless



Gold steel  
stainless

Floors



Silestone  
Expo grey

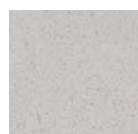

Silestone  
North white

# Structures

The structures for elevators provide us with a standardization and flexibility which entails certain advantages:

- **Standardization:**
  - Simple and swift installation process.
  - Swift and punctual delivery.
- **Flexibility:**
  - Adaptability to different types of installations and buildings, with structural liberty.
  - Wide range of finishing (stainless steel, zinc coating, galvanizing, etc). There are also standard finishing for glass and metal (matt or glossy finishing).
  - Wide colour spectrum with powder coating (epoxy).
  - Solutions according to the necessities of the customer.

- **Enclosures:**

Inside

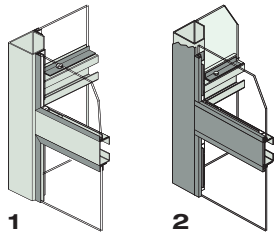

- 1. Frame steel sheet / aluminium
- 2. Frame steel sheet / aluminium + Cladding structure

Outside

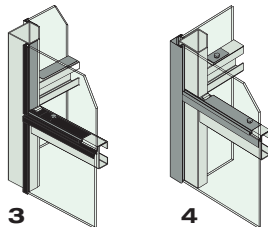

- 3. Frame steel sheet / aluminium
- 4. Frame steel sheet / aluminium + Cladding structure

Inside

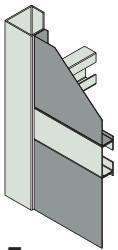

- 5. Continuous enclosure

Outside

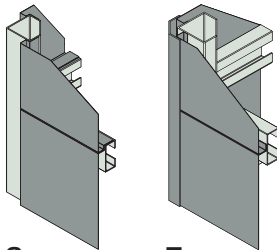

- 6. Continuous enclosure
- 7. Continuous enclosure + Cladding structure

- **Colours:**

Availability of diferent RAL colours. Please ask.



Speciali Model



R2 Model

- **Standard Finishing:**

Glitter finishing (matt)

Glossy finishing



Barcelona • Lisbon • Madrid • Seville • Valencia



**Headquarters Spain**

Parque Empresarial Táctica  
C/ Coeters,27  
46980 Paterna  
Telf.: (+34) 961 345 379  
Fax: (+34) 961 345 351

E-mail: [export@raloe.com](mailto:export@raloe.com)

[www.raloe.com](http://www.raloe.com)

Available in different languages



092011